

(19)



Europäisches Patentamt
European Patent Office
Office européen des brevets



(11)

EP 1 271 490 A2

(12)

EUROPEAN PATENT APPLICATION

(43) Date of publication:
02.01.2003 Bulletin 2003/01

(51) Int Cl.7: **G11B 7/007**

(21) Application number: 02015540.4

(22) Date of filing: 20.10.1997

(84) Designated Contracting States:
DE FR GB

(30) Priority: 23.10.1996 JP 28049196

(62) Document number(s) of the earlier application(s) in accordance with Art. 76 EPC:
00102960.2 / 1 006 514
97944184.7 / 0 936 601

(71) Applicant: **MATSUSHITA ELECTRIC INDUSTRIAL CO., LTD.**
Kadoma-shi, Osaka 571-8501 (JP)

(72) Inventors:
• **Takemura, Yoshinari**
Osaka 566 (JP)

- **Ishida, Takashi**
Kyoto 614 (JP)
- **Ohara, Shunji**
Higashiosaka-shi, Osaka 578 (JP)
- **Sato, Isao**
Neyagawa-shi, Osaka 572 (JP)

(74) Representative: **Balsters, Robert et al**
Novagraaf International S.A.
25, avenue du Pailly
1220 Les Avanchets - Geneva (CH)

Remarks:

This application was filed on 11 - 07 - 2002 as a divisional application to the application mentioned under INID code 62.

(54) **Optical disk**

(57) A rewritable optical disk is disclosed which is compatible with a read-only optical disk in which a read-only area has tracks divided into a plurality of first sectors, signals being pre-recorded in at least one of these first sectors under a predetermined reproduction format. The rewritable optical disc comprises a read-only area located in an inner portion in which read-only tracks are

formed, and a rewritable area located in an outer portion in which rewritable tracks are formed. Each of the rewritable tracks is divided into second sectors, and the signal is recordable in the second sectors under a predetermined recording format which includes the predetermined reproduction format as a part thereof and further includes another part specific to the predetermined recording format.

FIG.2

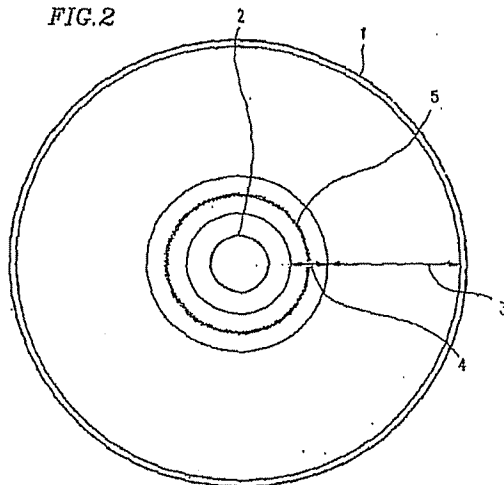

EP 1 271 490 A2

Description

TECHNICAL FIELD

[0001] The present invention relates to an optical disk, and more particularly relates to a rewritable optical disk having a control data signal representing the type of the disk and the like.

BACKGROUND ART

[0002] In recent years, various types of optical disks, for example, read-only types such as a CD and a CD-ROM and types which allow for data recording such as a data addition type and a rewritable type, have been widely used. Some of such optical disks of the read-only type, the data addition type, and the rewritable type are the same in appearance and the like, though they are different in type from each other.

[0003] Some of the optical disks are different from others in format type and parameters to be set at recording or reproduction. Information on the format type and information for setting parameters are therefore prerecorded as control data signals in a predetermined region of the disk. These control data signals are required to be read by a drive for reproducing/recording data from/on the optical disk before various settings for the drive are performed.

[0004] A method for recording such control data signals will be described, using a "130 mm rewritable optical disk" as an example. The "130 mm rewritable optical disk" has a format defined by JIS X6271. There are two types of formats: Format A where continuous grooves are formed spirally on a disk, and lands between adjacent grooves are used as tracks for recording signals; and Format B where marks for sampling are formed on a disk to allow for tracking control by a sample servo method. The two formats are common in the configuration of a control information track where the control data signals are recorded. That is, the control information track is specified to have a PEP region, an inner SFP region, and an outer SFP region.

[0005] The PEP region is located on the innermost portion of the disk, where prerecord marks (also called embossed pits), obtained by modulating with low-frequency phase-modulated recording codes, are used. All the marks in the PEP region are arranged so as to be aligned in the radial direction of the disk. This arrangement is schematically shown in Figure 3A. Each prerecord mark and each space between adjacent prerecord marks are two channel bits long. One PEP bit cell has a length of 656 ± 1 channel bits. Referring to Figure 4, the information of the PEP bit cell is represented by a phase-modulated recording code. A PEP bit cell where marks are formed in the first half thereof represents logical 0, while that where marks are formed in the second half thereof represents logical 1. A total of 561 to 567 PEP bit cells per track are recorded on the disk.

[0006] The PEP region has a track format shown in Figure 5A, which includes three sectors 177. Figure 5B shows a sector format of each sector. The numbers shown in the figures represent the numbers of PEP bit cells allocated to respective signals. A data region of the sector format where various control signals are recorded has a capacity of 18 bytes (144 PEP bits). For example, a signal representing the format (Format A or B) to be used by the disk is recorded in byte 0. The details on other control signals to be recorded on the data region are specified in the aforementioned JIS standard. The description thereof is therefore omitted here.

[0007] When the above PEP region is illuminated with light with an optical head or the like, light is focused on a signal recorded surface of the disk by focusing control. Since marks are aligned in the radial direction in the PEP region, signals can be reproduced without tracking control.

[0008] Figure 3A shows an example of a beam track. The portion where no marks are formed serves as a mirror, producing a large amount of reflection light. The portion where marks are formed diffracts reflection light depending on whether or not the marks exist at respective positions on the disk. Therefore, the average level of the amount of reflection light is low compared with that of the mirror portion.

[0009] Figure 3B shows a change in amount of reflection light. Since the repetition frequency of the marks is higher than the period of the PEP bit cells, mark signal components can be eliminated by limiting the band for a reproduction signal. The waveform of the reproduction signal obtained by band limit is shown in Figure 3C. The information of each PEP bit can be detected by comparing the level of the reproduction signal.

[0010] Then, the inner and outer SFP regions will be described. The same information is recorded in the inner and outer SFP regions. Prerecord marks are recorded in the inner and outer SFP regions under a standard user data format. A 512 B region is allocated for the control data signals. For example, the same information as the 18 B information recorded in the PEP regions is recorded in bytes 0 to 17. The details on other control information to be recorded in this region are specified in the aforementioned JIS standard. The description thereof is therefore omitted here.

[0011] Figure 6 shows a standard user data format where the user data capacity is 512 B and Format A is used. The numbers shown in this figure represent the numbers of bytes (B) allocated to respective signals. The capacity of the data region becomes 650 B including an error correction code, re-synchronization bytes, and control bytes in addition to the 512 B user bytes.

[0012] This sector for recording signals in the data region also includes the following regions: a prerecorded address section composed of a sector mark (SM) indicating the head of the sector, a VFO region for synchronizing clock reproduction, an ID region indicating the address of the sector, an address mark (AM) indicating the

head of the ID region, and the like; and regions for re-writing data, such as an offset detection region (ODF), an ALPC used for detection of laser output, and a buffer region provided to avoid overlap with a subsequent sector.

[0013] The total capacity of the sector is therefore 746 B. Although the control data recorded in the SFP regions are prerecord marks, the capacity of 746 B is also required to record the 512 B control signals, since the control data is recorded under the user data format.

[0014] In recent years, read-only optical disks in which digitized and compressed image and sound signals are recorded have been proposed. Figures 7A to 7C show an example of a sector format of one of such read-only optical disks proposed as a DVD.

[0015] A 2048 B unit of information data such as image and sound is recorded in one sector. This unit is called a first data signal. The sector also includes a 4 B data ID indicating an address such as a sector number, a 2 B IED for error detection of the data ID, a 6 B RSV as reservation, and a 4 B EDC for error detection of the entire sector. Such one sector including these regions is called a first data unit. Figure 7A shows a configuration of the first data unit which has a data length of $2048 + 4 + 2 + 6 + 4 = 2064$ (B).

[0016] The information data (2048 B) is scrambled in the following manner. A shift register is constructed so that so-called M-series data is generated. An initial value is set for the shift register, and is sequentially shifted in synchronization with the data, so as to generate pseudorandom data. An exclusive-OR between the generated pseudorandom data and the information data to be recorded is calculated every bit. Thus, the information data (2048 B) is scrambled.

[0017] A total of 16 sectors of the thus-scrambled first data units are put together to constitute an error correction code of lead Solomon coding. In such an error correction code, each data unit constituting one sector is arranged in an array of $172 \text{ B} \times 12 \text{ rows}$ and a total of 16 sectors of such data units are put together to constitute an array of $172 \text{ B} \times 192 \text{ rows}$. A 16 B outer code is added to each column of the array, and then a 10 B inner code is added to each row of the resultant array. As a result, a data block of $182 \text{ B} \times 208 \text{ rows}$ (37856 B) is formed. This data block is called an ECC block. This configuration is shown in Figure 7B.

[0018] Then, the ECC block is interleaved so that the 16 B outer codes are included in the respective sectors. Thus, the data capacity of each sector becomes $182 \text{ B} \times 13 \text{ rows} = 2366 \text{ B}$.

[0019] The resultant data is then modulated with a recording code. A RLL code where the run length after modulation is limited is used as the recording code. As an example, a 8/16 conversion code which converts 8-bit data into 16-channel-bit data is used. This conversion is conducted based on a predetermined conversion table. DC components included in the recording code can be suppressed by controlling the code selection,

though the detailed description of this control is omitted here.

[0020] At this time, the minimum and maximum bit lengths are limited to 3 and 11 channel bits, respectively. In order to secure synchronization at reproduction, a synchronization code is inserted. A 2 B synchronization code is inserted every 91 B, i.e., a half of one row of 182 B. As the synchronization code, several different codes with a length of 32 channel bits having patterns which normally do not appear in the 8/16 conversion code are predetermined. This period of 93 B data including the synchronization code is called a frame. This configuration is shown in Figure 7C. Thus, the data capacity of each sector is now $186 \text{ B} \times 13 \text{ rows} = 2418 \text{ B}$.

[0021] In a read-only DVD having a single signal recording surface, data is recorded by forming pits on the disk from the inner circumference thereof toward the outer circumference at a constant linear velocity (i.e., by CLV driving) in accordance with the above-described sector format. A disk having double signal recording surfaces has also been proposed, though the description thereof is omitted here.

[0022] Figure 8 shows an arrangement of signal recording areas of the read-only DVD. A lead-in area is located on the innermost portion of the disk, which starts at a radius of 22.6 mm. A data area where information data such as image and sound is recorded starts at a radius of 24.0 mm and ends at a radius of 58.0 mm at maximum. A lead-out area follows the data area. The maximum radius of the lead-out area is 58.5 mm. The sector address is 30000 in the hexadecimal notation: (denoted as 30000h) at the head of the data area, and increases by 1h every sector toward the outer circumference of the disk. In the lead-in area, the sector address decreases by 1h every sector toward the inner circumference of the disk.

[0023] The control information such as control data is recorded in the lead-in area under the sector format described above. In the lead-in area, a reference code is recorded over two ECC blocks covering sector addresses starting from 02F000h to 02F020h. The reference code is used for identification of the disk manufacturer, adjustment, and the like. The control data is recorded over 192 blocks covering sector addresses from 02F200h to 02FE00h. In the other sectors in the lead-in area, information data is recorded as 00h under the same sector format as that described above.

[0024] A rewritable DVD which is compatible in format with the above-described read-only DVD has been proposed. In such a rewritable optical disk, spiral or concentric grooves are formed on a disk substrate, and a recording film is formed on the substrate to define tracks along the grooves. In order to increase the recording capacity, both grooves and lands between adjacent grooves are used as recording tracks.

[0025] Each track is divided into a plurality of sectors as units for data recording and reproduction. Address information is added to each sector so that the position

of required information data can be managed to facilitate high-speed data retrieval. A header region which includes an ID signal representing the address information of the sector is provided at the head of the sector.

[0026] In order to secure the compatibility with the read-only DVD, the rewritable DVD has a format so that the 2418 B data of one sector of the read-only DVD can be recorded in a user data region of one sector of the rewritable DVD as a unit. This data is called a second data signal.

[0027] The sector format for the rewritable DVD also requires an ID region indicating the address number of the sector and a buffer region, as in the case of the optical disk according to the aforementioned JIS standard. The capacity of the entire sector including these regions is preferably a multiple of the frame length (93 B) of the format for the read-only disk.

[0028] Figure 9 shows an example of the format for the rewritable DVD which satisfies the above requirements. The 2048 B data (first data signal) is arranged under a format similar to that used for the read-only DVD described above, to obtain 2418 B data (second data signal), and the resultant 2418 B data is recorded in a data region **91** of the sector layout shown in Figure 9. A 1 B postamble region **92** follows the data region **91**. In the case of the 8/16 conversion code described above, the end of the recording code should be identified so that the converted data can be correctly decoded. A pattern obtained by modulating a predetermined code in accordance with a modulation rule is recorded.

[0029] A PS region **93** precedes the data region, where a presync signal is recorded to indicate the start of the data region and obtain byte synchronization. As the presync signal, a code with a length of 3 B (48 channel bits) which has high autocorrelation is predetermined. A VFO region **94** precedes the PS region **93**. The VFO region **94** is a region where a signal with a specific pattern is recorded to obtain prompt and stable clocking of a PLL of a reproduction circuit.

[0030] The specific pattern of the signal is, for example, a repetition of a 4-channel-bit pattern, i.e., "... 1000 1000 ..." as represented in NRZI coding. The length of the VFO region **94** is 35 B to secure the frequency of the inversion and the duration required for stable clocking.

[0031] A first guard data region **95** precedes the VFO region **94**, while a second guard data region **96** follows the PA region **92**. In a rewritable recording medium, the head and end portions of the recording area degrade after repeated recording and deletion. The guard data regions are therefore required to have a length large enough to prevent the degradation from affecting the area of the VFO region to the PA region. It has been found from experiments that the lengths of the first and second guard data regions should be 15 B and 45 B, respectively. Data to be recorded in these guard data regions are, for example, the same repetition of the 4-channel-bit pattern as that used for the VFO region, i.e., "... 1000

1000 ...".

[0032] A gap region **97** is provided for setting a laser power. The length of the gap region **97** is 10 B to secure the time required for the setting of the laser power. A buffer region **98** is provided to secure a time width where no data is recorded to ensure that the end of the recording data does not overlap a subsequent sector even if a variation in rotation of a disk motor or disk eccentricity occurs. The length of the buffer region **98** is 40 B.

[0033] The above region constitute an area where rewritable data is recorded and has a total length of 2567 B. The signal recorded in this area is called a third data signal.

[0034] A mirror region **99** has a length of 2 B to secure the time required for determining an offset of the servo tracking.

[0035] Next, a header region will be described. As shown in Figure 9, a first half **19** and a second half **20** of the header region are displaced from the center line of the groove in the radial directions by about a quarter of the pitch of the groove, so that the header region can be read from both the groove track and the land track. The first half **19** and the second half **20** are displaced in the opposite directions from each other from the center line of the groove. Referring to Figure 9, the header region includes four sector ID signals (PIDs). For the groove track, for example, **PID1** and **PID2** in the first half are displaced toward the outer circumference of the disk, while **PID3** and **PID4** in the second half are displaced toward the inner circumference of the disk.

[0036] A 4 B Pid region representing the address information of the sector is provided in each sector ID signal PID. In the Pid region, 3 B is allocated for the sector number and the remaining 1 byte is allocated for various types of information such as the PID number. In a Pid3 region **113** and a Pid4 region **118**, the address information of the sector on the groove track having the center line from which the PIDs are displaced is recorded.

[0037] In a Pid1 region **103** and a Pid2 region **108**, the address information of the sector on the land track which is on the outer side of the adjacent groove track is recorded. IED regions **104**, **109**, **114**, and **119** with a length of 2 B represent an error detection code for the preceding respective Pid regions. The data in the Pid regions and the IED regions are modulated with the 8/16 conversion code described above. In order to identify the end of the conversion code, 1 B postamble (PA) regions **105**, **110**, **115**, and **120** are provided.

[0038] AM regions **102**, **107**, **112**, and **117** precede the respective Pid regions, where address mark signals are recorded to indicate the start of the Pid regions and obtain byte synchronization. Each address mark signal has a length of 3 B (48 channel bits), and a code having a pattern which does not appear in the 8/16 conversion code is predetermined.

[0039] VFO regions are provided at the heads of the respective sector ID signal PIDs. As in the aforementioned VFO region, the repetition of the 4-channel-bit

pattern, "... 1000 1000" is used. As described above, in the header region, the first half PID1 and PID2 and the second half PIDs and PID4 are displaced in the opposite radial directions. Accordingly, in order to resume the bit synchronization, the first VFO regions 101 and 111 located at the heads of the first and second halves of the header region are made long. On the contrary, the second VFO regions 106 and 116 of the first and second halves may be short since they are only required for re-synchronization. For example, the lengths of the first and second VFO regions are 36 B and 8 B, respectively.

[0040] As a result, the total length of one sector of the rewritable DVD is 2697 B. Thus, the length of one sector of the rewritable DVD is larger than that of one sector of the read-only DVD by 279 B (corresponding to three frames).

[0041] As described above, in the rewritable DVD, as in the read-only DVD, it is necessary to prerecord the control data signals indicating various types of control information. This can be performed using the prerecord marks, as in the case of the above-described "130 mm rewritable optical disk", under the sector format used for the "130 mm rewritable optical disk". The length of one sector of the rewritable DVD is larger than that of one sector of the read-only DVD by about 10% or more as described above. Since the control data signals are recorded at the fabrication of the disk and need not to be rewritten, this increase in the sector length is unnecessary for the recording of the control data signals. This unnecessary increase in sector length is therefore disadvantageous for DVDs which are requested to have a large capacity.

[0042] A drive for DVDs is required to be able to record or reproduce both read-only DVDs and rewritable DVDs. However, the read-only DVDs and the rewritable DVDs are different in sector format. The type of the disk can be identified by reading the control data signal. However, in order to read the control data signal, the format of the disk must be identified to locate the recorded position of the control data signal.

[0043] In order to identify the type of the disk, a region with the same sector format may be set for both the read-only type and the rewritable type using prerecord marks so as to record a signal indicating the type of the disk in the region, as in the case of the PEP region of the above-described "130 mm rewritable optical disk". This common region is first reproduced at the activation of the disk to identify the type of the disk. Once the type of disk is identified, the control data on the disk can be reproduced in accordance with the format for the disk. However, as in the case of the "130 mm rewritable optical disk", the signal indicating the type of the disk recorded on the common area is the signal recorded as part of the control data signal. Recording the same control data signal on two different regions results in redundancy of the recording area. The redundancy of the recording area is disadvantageous for DVDs which are re-

quired to have a large capacity.

[0044] In view of the foregoing, the objective of the present invention is to provide an optical disk in which control data signals are recorded under a format which can be easily read regardless of the type of the optical disk, a read-only DVD or a rewritable DVD, and redundancy is reduced to improve the recording capacity.

DISCLOSURE OF THE INVENTION

[0045] The optical disk of the present invention is defined in the appended claims.

[0046] Accordingly, a control data signal can be recorded in the read-only area where a region for recording header information is not provided. This means that the control data signal is recorded under a reproduction format for the first sectors in the read-only area which is lower in redundancy than the sector format for the second sectors in the rewritable area. This improves the efficiency of the recording region of the rewritable optical disk.

[0047] Accordingly, a control data signal is recorded in the read-only area located on the inner portion of the optical disk, as in the read-only disk, under the same format as that used in the read-only disk.

[0048] As a result, a drive which is compatible with both the rewritable optical disk and the read-only optical disk can reproduce data from whichever optical disk mounted in the drive, the rewritable optical disk or the read-only optical disk, under the same sector format. The drive can also detect the control signals recorded on both types of optical disks, and activate these optical disks easily. This eliminates the necessity of providing a special region such as the PEP region described above.

BRIEF DESCRIPTION OF THE DRAWINGS

[0049]

Figure 1 is a schematic view of a layout of areas of an example according to the present invention.

Figure 2 is a schematic view of an appearance of an optical disk of the example according to the present invention.

Figures 3A, 3B, and 3C are schematic views of an array of marks in a PEP region of a conventional example.

Figure 4 is a schematic view of forms of bit cells in the PEP region of the conventional example.

Figures 5A and 5B are schematic views of formats of the PEP region of the conventional example.

Figure 6 is a schematic view of a sector format of a

conventional optical disk.

Figures 7A, 7B, and 7C are schematic views of sector formats of a read-only area of the example according to the present invention.

Figure 8 is a schematic view of a layout of areas of a conventional read-only DVD.

Figure 9 is a schematic view of a sector format of a rewritable area of the example according to the present invention.

Figure 10 is a schematic view showing the boundary portion between the rewritable area and the read-only area of the example according to the present invention.

BEST MODE FOR CARRYING OUT THE INVENTION

[0050] Hereinbelow, the present invention will be described by way of example with reference to the accompanying drawings.

[0051] As an example of the present invention, a rewritable DVD which is compatible in format with the conventional read-only DVD described above will be described. The appearance of the optical disk is shown in Figure 2. Figure 2 shows an optical disk 1, a center hole 2, and a rewritable area 3 for recording data. Spiral grooves are formed on the rewritable area 3 for recording data, and the grooves and lands between adjacent grooves are used as tracks. A read-only area 4 is provided on the inner side of the rewritable area 3. In this example, a control data zone 5 where control data representing various types of detailed information on the disk is recorded is provided in the read-only area 4.

[0052] The sector format shown in Figure 7 described above is used for the read-only area 4. That is, a 2048 B first data signal together with a data ID, an error correction code, a synchronization code for re-synchronization, and the like constitute data with a sector length of 2418 B. The resultant data is prerecorded on the disk as a pit array.

[0053] The sector format shown in Figure 9 described above is used for the rewritable area 3. That is, user data is divided into 2048 B units of first data signals. Each first data signal is transformed into a 2418 B second data signal having the same configuration as the format for the read-only area (Figure 7). Data required to provide the rewritability is added to the second data signal to obtain a 2567 B third data signal. A space for recording this size of data is secured on a track, and a 128 B header region and a 2 B mirror region are added to the third data signal, thereby to obtain a rewritable sector region with a total length of 2697 B. This format is therefore a format in which the 2418 B data of one sector of the read-only DVD can be recorded in the user data region of one sector of the rewritable DVD as a unit

without any change.

[0054] In order to indicate the address numbers of the sectors on the adjacent groove and land tracks, the first half 19 and the second half 20 of the header region of the rewritable area are displaced from the center line of the groove in the opposite radial directions from each other by about a quarter of the pitch of the groove.

[0055] In order to achieve the above arrangement, the header regions need to be aligned in the radial direction of the disk. This sector arrangement results in having the same number of sectors for all tracks including inner and outer tracks of the disk, thereby reducing the recording density of the outer tracks.

[0056] In order to overcome the above problem, the rewritable area is divided into a plurality of zones. The number of sectors per track is the same within each zone, and is increased by one sector as the zones are closer to the outer circumference of the disk from the inner circumference thereof.

[0057] For example, when data is recorded on a phase-change recording material under the format shown in Figure 9 using a semiconductor laser with a wavelength of 650 nm and an objective lens with an NA of 0.6, the minimum bit length of about 0.41 μm is realized. If the radial position of the innermost end of the rewritable area is set at 24.0 mm which is substantially the same as the radial position of the innermost end of the data area of the read-only disk, 17 sectors can be formed on each track in the innermost zone. By increasing the number of sectors per track by one sector for each zone while the minimum bit length is kept substantially the same, a total of 24 zones are obtained for a disk with a radius of 12 cm, and 40 sectors are formed on each track in the outermost zone. In this case, the total user data capacity of all zones is about 2.6 GB.

[0058] When data is recorded on/reproduced from the disk with the above sector arrangement, the following two driving methods may be employed: an MCAV driving method in which, while the disk is rotated at a constant rotational speed, the frequency of the recording/reproduction is changed every zone; and a ZCLV driving method in which the rotational speed is changed every zone so that the linear velocity is substantially the same among the zones, while the rotational speed is fixed within each zone.

[0059] Hereinbelow, a mastering process for fabricating the disk with the above format will be described. The mastering includes recording signals according to the format using a light source with a short wavelength such as a gas laser while rotating a glass plate to which a photosensitive agent (resist) is applied.

[0060] An EO modulator or the like is irradiated with laser light from the light source. When electric signals according to the format described above are applied to the EO modulator, the intensity of the light passing through the EO modulator is modulated. The modulated light is focused with the objective lens onto the glass plate to illuminate the photosensitive agent.

[0061] By developing the glass plate, prerecord pits and grooves are formed on the glass plate. A metal mask is formed by plating using the plate as a resist original disk. A resin disk substrate is then formed based on the metal mask, though detailed description is omitted here. In this mastering process, a turn table for rotating the glass plate rotates with high precision. Accordingly, a turn table with a large inertia force is used, and thus it is difficult to change the rotational speed instantaneously during the mastering.

[0062] In this example, as described above, the read-only area 4 is provided on the inner portion of the disk as shown in Figure 2. The same sector format as that used for the read-only DVD is used for the read-only area 4.

[0063] However, the read-only DVD is driven by the CLV driving method where the linear velocity is constant as described above, while the rewritable DVD is driven by the MCAV or ZCLV driving method. If the different driving methods are employed for the read-only area and the rewritable area, switching of the rotational speed is required. Switching of the rotational speed during the mastering of the disk is difficult as described above.

[0064] In this example, therefore, data is recorded on the read-only area at a constant rotational speed of the disk. The read-only area of the resultant disk is driven by the same driving method as that for the rewritable area, i.e., the MCAV or ZCLV driving method. Since the sectors in the read-only area are arranged at the constant rotational speed, the period of the reproduction of the sectors becomes constant. As a result, even if the address of a sector fails to be reproduced, it can be easily interpolated from the positions of the preceding and following sectors.

[0065] The thickness of the photosensitive agent applied to the glass plate in the mastering process is made substantially uniform. This thickness corresponds to the depth of the grooves in the rewritable area.

[0066] For example, the depth of the grooves in the rewritable area is determined to be optically about $\lambda/8$ so as to obtain a large tracking signal. In the read-only area, the depth of the grooves, which corresponds to the depth of the pits, is determined to be optically about $\lambda/4$ so as to obtain a large contrast of reproduction signals. The depth of the pits in the read-only area is therefore larger than that of the grooves in the rewritable area. It is difficult to change the depth of the grooves and the pits between the read-only area and the rewritable area of the same disk. In this example, therefore, the depth of the pits in the read-only area is made substantially the same as the depth of the grooves in the rewritable area.

[0067] More specifically, the depth of the pits in the read-only area is made smaller than the depth of the pits in the read-only disk (optically about $\mu/4$). This causes a failure in obtaining a large contrast of the reproduction signals. To compensate for this, the length of the short-

est pits is made larger than that of the read-only disk. For example, the length of the shortest pits is $0.41 \mu\text{m}$ which is the same bit length as that used in the rewritable area.

[0068] In this example, the sector format is different between the rewritable area and the read-only area. While the length of the sector is 2418 B in the read-only area, it is 2697 B in the rewritable area. The innermost zone of the rewritable area has 17 sectors per track as described above. The number of sectors per track in the read-only area when the minimum bit length is substantially the same is calculated as follows.

$$17 \times 2697 / 2418 = 18.9...$$

In consideration of the facts that the read-only area is located nearer the inner circumference of the disk than the rewritable area and that the number of sectors per track should be an integer, the number of sectors per track in the read-only area is determined to be 18 sectors as an integer not exceeding the above value.

[0069] In this example, the track pitch is substantially the same in the rewritable area and the read-only area.

Figure 10 schematically shows the tracks at the boundary between the rewritable area and the read-only area. Portion (a) denotes the read-only area and portion (b) denotes the rewritable area. In the read-only area, prerecorded pits 11 are formed along each track 10. A track pitch 12 is determined by the degree of crosstalk of the reproduction signals and the like. For example, the track pitch is $0.74 \mu\text{m}$ in the read-only DVD.

In the rewritable area (b), grooves 14 are formed. The grooves are used as groove tracks 17 and lands between the grooves are used as land tracks 18. A track pitch 13, which is a gap between the adjacent groove track and land track, is substantially the same as the track pitch in the read-only area.

The groove pitch is therefore double the track pitch. The track widths of the groove tracks and the land tracks are made substantially the same. Accordingly, the groove width and the track pitch should be substantially the same. In order to form wide grooves, the laser beam used for recording data needs to be large in the radial direction in the mastering process described above.

When such a wide beam is used for recording in the read-only area, the resultant pits are large in width, thereby narrowing the gap between the pits in the adjacent track. This increases crosstalk of the reproduction signals. To avoid this problem, two different laser beams are used; one is for recording small pits in the read-only area and the other is wide for forming grooves in the rewritable area.

However, at the switching of the laser beams for pits and for grooves at the boundary between the rewritable area and the read-only area, if the spot positions of the two laser beams on the disk surface are de-

viated from each other, the recorded pit array and the groove are not formed in succession, but overlap each other or are spaced apart from each other. It is practically difficult to put the spot positions of the two laser beams in conformity with each other two-dimensionally on the disk surface. It is therefore impossible to connect the rewritable area and the read-only area with the same track pitch at the boundary thereof.

[0074] In the read-only area, the pit array is continuously recorded starting from the innermost end of the area. At the outermost end of the read-only area, therefore, errors may be accumulated, and thus the position of the end of the last sector may be shifted.

[0075] In this example, therefore, a connection zone is provided between the rewritable area and the read-only area. A first example of such a connection zone is shown as portion (c) in Figure 10. This connection zone of the first example constitutes a flat (mirror) zone since no signal recording is required. Positioning of the two beams is practically possible when the width of the connection zone is 1 μm or more.

[0076] If the connection zone is wide, a tracking error signal is not generated when the connection zone is irradiated with laser light for servo tracking at the reproduction of data from the resultant disk with a drive. This makes the operation unstable. When a resultant disk is mounted on a drive and rotated, eccentricity more or less occurs. If the size (width in the radial direction) of the mirror zone is smaller than the minimum amount of the eccentricity, the laser beam from the drive necessarily crosses the pit array in the read-only area or the groove in the rewritable area during one rotation of the disk. The allowance of the eccentricity amount for a normal disk is about $\pm 50 \mu\text{m}$ at maximum. Therefore, in consideration of the minimum amount of the eccentricity, the width of the mirror zone in the radial direction may be about 5 μm . The mirror zone with this width corresponds to 2 to 8 tracks when calculated with the above track pitch. In Figure 10, virtual tracks 15.

[0077] A second example of the connection zone according to the present invention will be described. The first example of the connection zone constitutes a mirror zone as described above. In the second example of the connection zone, dummy data is recorded in the connection zone. As the dummy data, the repetition of the 4-channel-bit pattern, "... 1000 1000 ...", used for the VFO region shown in Figure 9 is used.

[0078] The dummy data is formed along the tracks 15 shown in Figure 10 covering two to three tracks. Then, one or two empty grooves without header regions are recorded (two to four tracks), followed by the formation of sectors with header regions. With this configuration, even if the spot positions of the laser beams are deviated from each other by about 1 μm , only the dummy data and the empty grooves overlap each other as described above, not destroying necessary data. By forming such a pit array, a tracking error is also detected stably in the connection zone.

[0079] In a third example of the connection zone according to the present invention, the dummy data in the connection zone has a sector configuration. For example, when dummy data under the format for the read-only area is recorded, sectors as shown in Figure 7 where the first user data is all 00h are formed. When dummy data under the format for the rewritable area is recorded, grooves of sectors with the header regions as shown in Figure 9 are formed. With this configuration, as in the above examples, even if the spot positions of the laser beams are deviated from each other by about 1 μm , only the sectors of dummy data overlap each other, not destroying necessary data.

[0080] Even if part of a sector fails to be read, no problem arises since it is dummy data. It is possible to set so that the addresses of the sectors in the connection zone are not usable. By forming such a sector array, a tracking error is also stably detected in the connection zone. Moreover, since the sector addresses can be detected, the positions of the respective sectors on the disk are identified, thereby facilitating the system management.

[0081] Figure 1 shows a layout of the areas of the rewritable optical disk according to the present invention. Figure 1 is a list showing respective zones in the areas in the order from the inner side to the outer side of the disk, together with the rough radial position of each zone, the address of the head sector of each zone, the number of blocks included in each zone, the number of tracks in each area, and the data ID number indicating the logical address of data. The sector address indicates the physical address of the sector, which is recorded in the Pid regions of the header region for each sector in the rewritable area and recorded as the data ID number for each sector in the read-only area.

[0082] The data ID number indicates the logical address of the data recorded in the sector. In the lead-in area and the lead-out area, the physical address and the logical address of each sector are the same. In each of the rewritable sectors in the lead-in and lead-out areas, the data ID number included in the rewritable data region (second data signal region) is the same as the physical address of the sector. The sectors in the data area are all rewritable sectors. The data ID number in each of these sectors indicates the logical address of data recorded in the sector.

[0083] Referring to Figure 1, the read-only area is located on the inner portion of the disk. The innermost end of the read-only area is at a radius of 22.6 mm of the disk, as in the case of the read-only DVD. The rewritable area starts at a radius of 24.00 mm of the disk, as in the case of the data area of the read-only DVD, and expands to the outer circumference of the disk.

[0084] The sector address is 30000 in the hexadecimal notation (denoted as 30000h) at the head of the rewritable area, and increases by 1h every sector toward the outer circumference of the disk. In the read-only area, the sector address decreases by 1h every sector to-

ward the inner circumference of the disk. A portion of the rewritable area over 256 ECC blocks (4096 sectors) from the head thereof is used for testing of the disk and the drive and the like. This portion of the rewritable area is included in the lead-in area which starts from the innermost end of the read-only area.

[0085] The data area follows the lead-in area for effecting the recording/reproduction of user data. The data area is divided into 24 zones from zone 0 to zone 23 as described above. The address of the head sector in the data area is 31000h. The lead-out area follows the data area.

[0086] Hereinbelow, the respective areas will be described in detail.

[0087] In the read-only area portion of the lead-in area, a reference signal zone for recording a reference code is provided over one ECC block covering sector addresses starting from 2F000h to 2F010h. The reference code is used for identification of the disk manufacturer, adjustment, and the like. A control data zone for recording control data signals is provided over 192 blocks covering sector addresses starting from 2F200h to 2FE00h. The other portions of the read-only area constitute blank zones, where the first data signal is recorded as 00h in each sector under the same sector format as that used for the other portions.

[0088] In this way, the same sector addresses as those used for the read-only DVD described above are used for the control data zone. With this arrangement, it is possible for a drive compatible with these two types of disks to always seek the same sector addresses to reproduce the control data signals from the sectors of the same addresses. Therefore, such a drive compatible with the two different types of disks can follow the same procedure to activate these disks.

[0089] The connection zone follows the read-only area to obtain a smooth shift from the read-only area to the rewritable area. As described above, in the first example of the connection zone, the mirror zone is provided over a portion corresponding to two to eight tracks. Since no signal is recorded in the mirror zone, the last sector of the final blank zone of the read-only area is the sector immediately before the sector address 30000h of the head sector in the rewritable area. The address of the last sector of the final blank zone is therefore 2FFFFh. The final blank zone includes 32 blocks covering sector addresses from 2FE00h following the control data zone to 2FFFFh.

[0090] In the second example of the connection zone, the connection zone includes dummy data and empty grooves having no sector address as described above. Accordingly, the address arrangement as that in the first example of the connection zone can be used.

[0091] In the third example of the connection zone, the dummy data has a sector configuration. Accordingly, the addresses of the sectors in the connection zone need to be preset to be unusable. The connection zone preferably has an integer number of tracks and corre-

sponds to an integer number of blocks.

[0092] For example, when the connection zone has eight tracks, it can correspond to nine blocks. In this case, the number of blocks in the final blank zone preceding the connection zone is reduced by nine blocks to 23 blocks (sector addresses from 2FE00h to 2FF6Fh). The nine blocks is added to the connection zone, to add a region covering sector addresses from 2FF70h to 2FFFFh to the connection zone. As a result, the connection zone is a zone covering sector addresses from 2FF70h to 30000h.

[0093] Although no address was allocated to the first and second examples of the connection zones, it is possible to allocate addresses to the connection zones which have no sector configuration, as in the case of the third example of the connection zone.

[0094] The portion of the rewritable area located in the lead-in area follows the connection zone. A guard track zone is first provided. The guard track zone starts at sector address 30000h and covers 32 blocks until sector address 301FFh. The guard track zone prevents other data from being destroyed due to an error such as tracking off caused when a test signal is recorded in a subsequent disk test zone. No data is recorded in the sectors in this zone.

[0095] The disk test zone is provided over the next 64 blocks covering sector addresses from 30200h to 305FFh for the testing of the disk quality and the like by the disk manufacturer. A drive test zone is provided over the next 112 blocks covering sector addresses from 30600h to 30CFFh for the testing such as setting of a laser power in a drive. Another guard track zone is provided over the next 32 blocks covering sector addresses from 30D00h to 30EFFh for effecting functions similar to those of the above guard track zone. A disk ID zone is provided over the next eight blocks covering sector addresses from 30F00h to 30F7Fh for recording copying management information. DMA zones are provided over the next eight blocks covering sector addresses from 30FB0h to 30FFFh for disk defect management.

[0096] The data area starts from the next address 31000h. The data area is divided into 24 zones from zone 0 to zone 23 as described above. Each zone is composed of 1888 tracks with an exception that zone 0 includes only 1647 tracks because the portion covering 256 blocks (4096 sectors) from the head belongs to the lead-in area as described above. The number of blocks included in each zone is shown in Figure 1 as an example. About 95% of the blocks in each zone are used as data blocks for recording user data. The logical address of each sector included in the data blocks represents an address obtained by adding the logical address to the physical address of the head sector in the data area (address 31000h in this example).

[0097] To the head and end of each zone in the data area, 48 to 80 sectors (corresponding to two or more tracks of each zone) are allocated as buffer sectors. Such buffer sectors are provided because at each

boundary of zones the header region sometimes fails to be continuous with the preceding sector, and therefore no data is recorded in the buffer sectors. Most of the remaining 5% of the blocks in each zone serve as spare sectors, which replace sectors in the data blocks when the latter become defective, to be used as sectors for data recording.

[0098] The physical address of the sector to be used for data recording changes by the above replacement. However, the logical address (data ID number) of the user data does not change as described above. Accordingly, a table associating the physical address of the sector with the logical address is prepared and recorded in the DMA zones.

[0099] The lead-out area follows zone 23, starting from the sector address 16B480h and expanding to the outermost circumference of the disk. Substantially the same zones as those in the portion of the rewritable area located in the lead-in area are allocated for the lead-out area. DMA zones are first provided at the head of the lead-out area for disk defect management-as described above. Thus, the four DMA zones, the DMA 1&2 zones on the inner side and the DMA 3&4 zones on the outer side, sandwich the data area. A disk ID zone is provided over the next eight blocks covering sector addresses from 16B500h to 16B57Fh for recording copying management information.

[0100] A guard track zone is provided over the next 32 blocks covering sector addresses from 16B580h to 16B77Fh. No data is recorded in this zone. A drive test zone is provided over the next 112 blocks covering sector addresses from 16B780h to 16BE7Fh for the testing such as setting of a laser power in a drive. A disk test zone is provided over the next 112 blocks covering sector addresses from 16BE80h to 16C57Fh for the testing of the disk quality and the like by the disk manufacturer. Another guard track zone is provided for over 3343 blocks covering sector addresses from 16C580h to 17966Fh. No data is recorded in this zone.

[0101] Thus, as is observed from the layout of the areas of the optical disk according to the present invention, the rewritable area starts at a radius of 24.00 mm of the disk as in the case of the data area of the read-only DVD. The address of the head sector in the rewritable area is the same as the address of the head sector in the data area of the read-only DVD. Also, the addresses of the sectors in the control data zone is the same as the addresses of the sectors in the control data zone of the read-only DVD. With this arrangement, it is possible for a drive compatible with these two types of disks to always seek the same sector addresses to reproduce the control data signals from the sectors of the same addresses. Therefore, such a drive compatible with the two different types of disks can follow the same procedure to activate these two types of disks. As a result, effective control of the drive is realized.

[0102] A layout of the rewritable area according to the present invention will be described. The logical address

of each sector included in the data blocks of the data area is the same as the address of each sector in the data area of the read-only DVD. While the address of the head sector in the data area of the read-only DVD is 30000h, the physical address of the head sector in the data area of the rewritable area is 31000h.

[0103] In this example, the logical address of the head sector is set at 30000h so as to be the same as the logical address of the head sector of the read-only DVD.

The logical address of each sector in the subsequent data blocks is obtained by adding the logical address to the logical address of the head sector (30000h in this example).

[0104] With this address setting, the logical addresses of the sectors in the data blocks overlap the addresses of the sectors in the portion of the rewritable area located in the lead-in area. This problem can be solved by adding to the data ID number the type of the area the sector belongs to, so that whether the sector is in the lead-in area or in the data area can be judged.

[0105] Thus, in the above example, the logical addresses of the sectors in the data blocks in the data area are the same as the addresses of the sectors in the data area of the read-only DVD. With this arrangement, it is possible for a drive compatible with these two types of disks to always seek the same sector addresses at the reproduction of user data. Therefore, such a drive compatible with the two different types of disks can follow the same procedure for the activation of these disks. As a result, effective control of the drive is realized.

[0106] In the above examples, the format shown in Figure 7 was used as the sector format for the read-only area, and the format shown in Figure 9 was used as the sector format for the rewritable area. The sector formats are not restricted to these, but the sector format for the "130 mm rewritable optical disk" described above can also be used.

INDUSTRIAL APPLICABILITY

[0107] Thus, according to the present invention, the optical disk includes the read-only area where a plurality of read-only tracks are formed and the rewritable area where a plurality of rewritable tracks are formed. Each of the plurality of read-only tracks is divided into a plurality of first sectors. A signal is prerecorded in at least one of the plurality of first sectors under a predetermined reproduction format. Each of the plurality of rewritable tracks is divided into a plurality of second sectors. A signal is recordable in at least one of the plurality of second sectors under a predetermined recording format including the predetermined reproduction format. The read-only area is located on the inner portion of the optical disk, while the rewritable area is located on the outer portion of the optical disk.

[0108] Accordingly, the control data signal is recorded in the read-only area where a region for recording header information is not provided. This means that the con-

control data signal is recorded under the sector format for the first sectors in the read-only area which is lower in redundancy than the sector format for the second sectors in the rewritable area. This improves the efficiency of the recording region of the rewritable optical disk. 5

[0109] Also, according to the present invention, the optical disk is compatible with the read-only optical disk, and includes the read-only area where a plurality of read-only tracks are formed and the rewritable area where a plurality of rewritable tracks are formed. Each of the plurality of read-only tracks is divided into a plurality of first sectors. A signal is prerecorded in at least one of the plurality of first sectors under a predetermined reproduction format. Each of the plurality of rewritable tracks is divided into a plurality of second sectors. A signal is recordable in at least one of the plurality of second sectors under a predetermined recording format including the predetermined reproduction format. The read-only area is located on the inner portion of the optical disk, while the rewritable area is located on the outer portion of the optical disk. 10 15 20

[0110] Accordingly, the control data signal is recorded in the read-only area located on the inner portion of the optical disk, as in the case of the read-only optical disk, under the same sector format as that used for the read-only optical disk. 25

[0111] As a result, a drive which is compatible with both the rewritable optical disk and the read-only optical disk can reproduce data from whichever optical disk mounted in the drive, the rewritable optical disk or the read-only optical disk, under the same sector format. The drive can also detect the control signals recorded on both types of optical disks, and activate these optical disks easily. This eliminates the necessity of providing a special region such as the PEP region described above. 30 35

Claims 40

1. An optical disk (1) compatible with a read-only optical disk which includes a read-only area having a plurality of read-only tracks, each of the plurality of read-only tracks being divided into a plurality of first sectors, signals being pre-recorded in at least one of the plurality of first sectors under a predetermined reproduction format, 45

the optical disk (1) comprising a read-only area (4) in which a plurality of read-only tracks are formed, and a rewritable area (3) in which a plurality of rewritable tracks are formed, 50

each of the plurality of rewritable tracks is divided into a plurality of second sectors,

a signal is recordable in at least one of the plurality of second sectors under a predetermined recording format which includes the predetermined reproduction format as a part thereof and further includes another part specific to the predetermined 55

recording format, and

the read-only area (4) is located on an inner portion of the optical disk (1), while the rewritable area is located on an outer portion of the optical disk (1).

FIG. 1

Radius (mm)	Zone name	Sector address (hex value)	No. of blocks	No. of tracks	Data ID
22.6	Blank (00h)	27AB0h			
23.86	Ref. signal	2F000h	1	1896	2F000h
23.83	Blank (00h)	2F010h	31		2F010h
23.98	Control data	2F200h	192		2F200h
	Blank (00h)	2FE00h	32		2FE00h
24.00	Connection	2FFFFh	2-8		
	Guard track	30000h	32		30000h
	Disk test	30200h	64		30200h
	Drive test	30600h	112		30600h
	Guard track	30D00h	32	1888	30D00h
	Disk ID	30F00h	8		30F00h
	DMA 1&2	30F80h	8		30F80h
24.18	Zone 0	31000h	1750		31000h
25.40	Zone 1	37D60h	2124	1888	377E0h
26.79	Zone 1	40220h			3F580h
56.13	Zone 22	158D80h			1491E0h
57.53	Zone 23	16B480h	4720	1888	16B480h
	DMA 3&4	16B500h	8		16B500h
	Disk ID	16B580h	8		16B580h
	Guard track	16B780h	32		16B780h
	Drive test	16B780h	112	1446	16B780h
	Disk test	16BE80h	112		16BE80h
	Disk test	16C580h	112		16C580h
58.60	Guard track	17966Fh	3343		17966Fh

FIG. 2

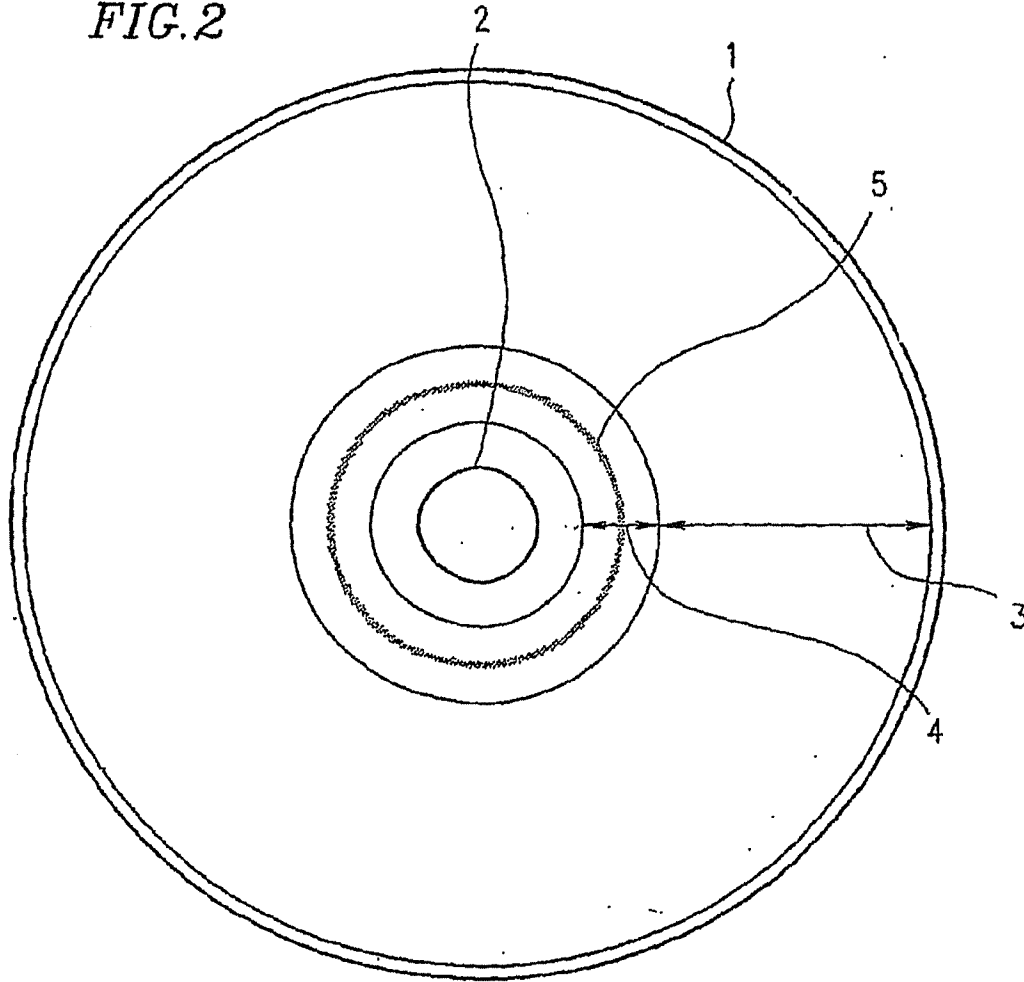

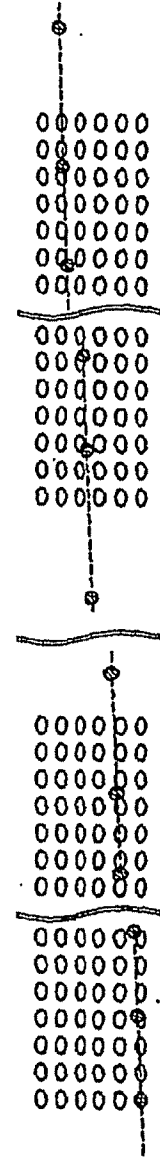

FIG. 3A

Beam track

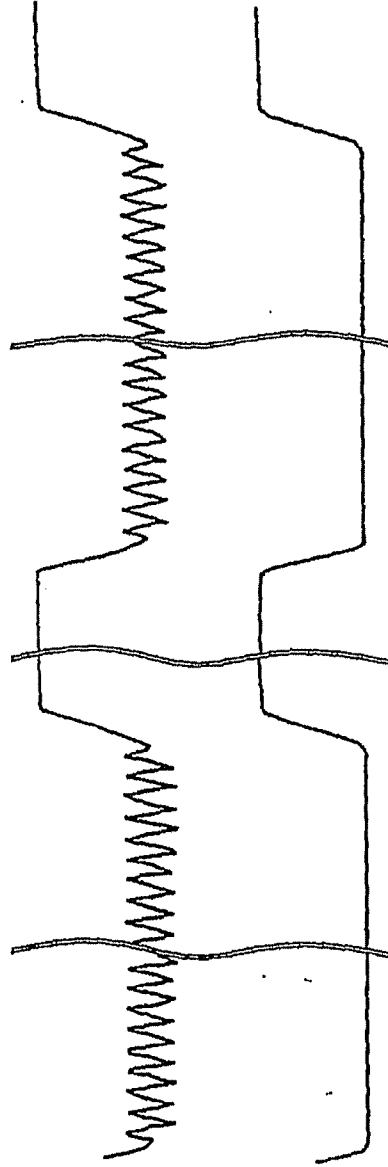

FIG. 3B

Reflection light amount

FIG. 3C

Band limit

FIG. 4
Form of bit cell in PEP region

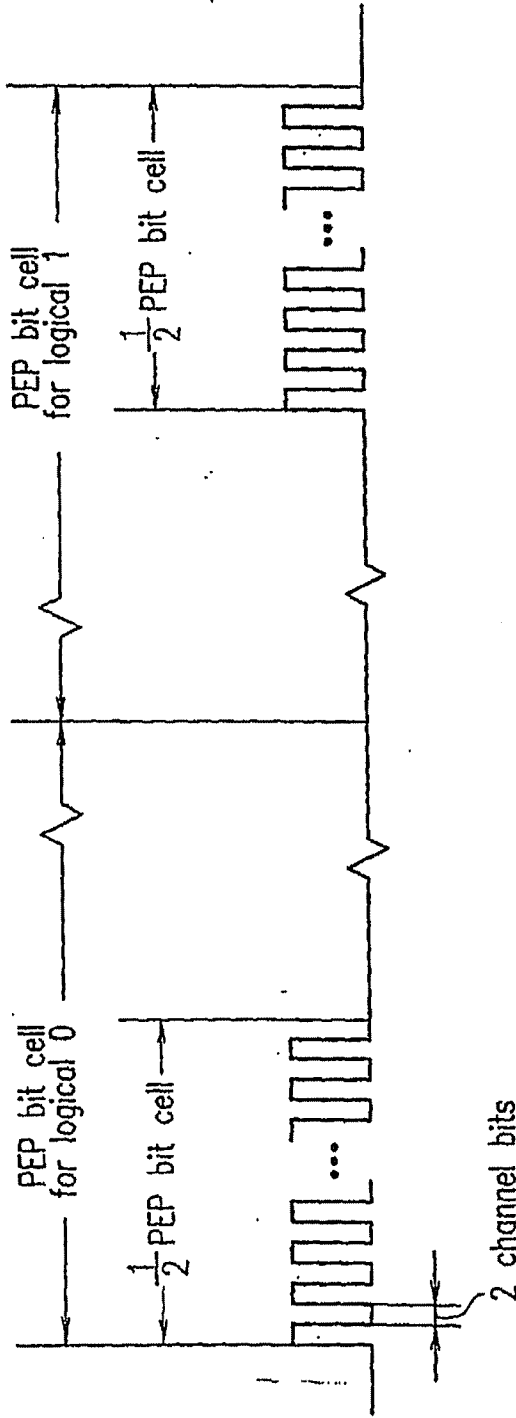

FIG. 5A

Track format for PEP region

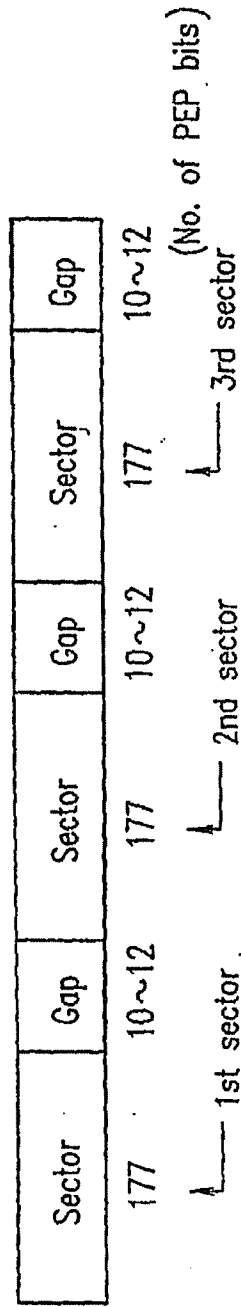
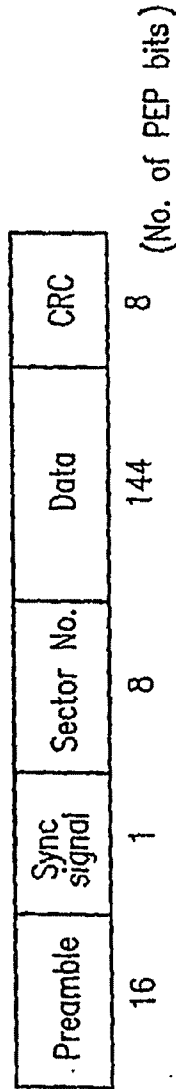

FIG. 5B

Sector format for PEP region



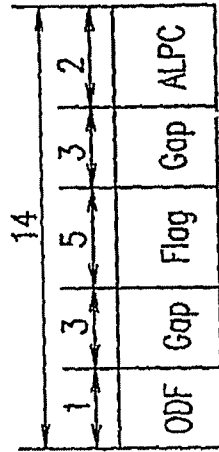

FIG. 6

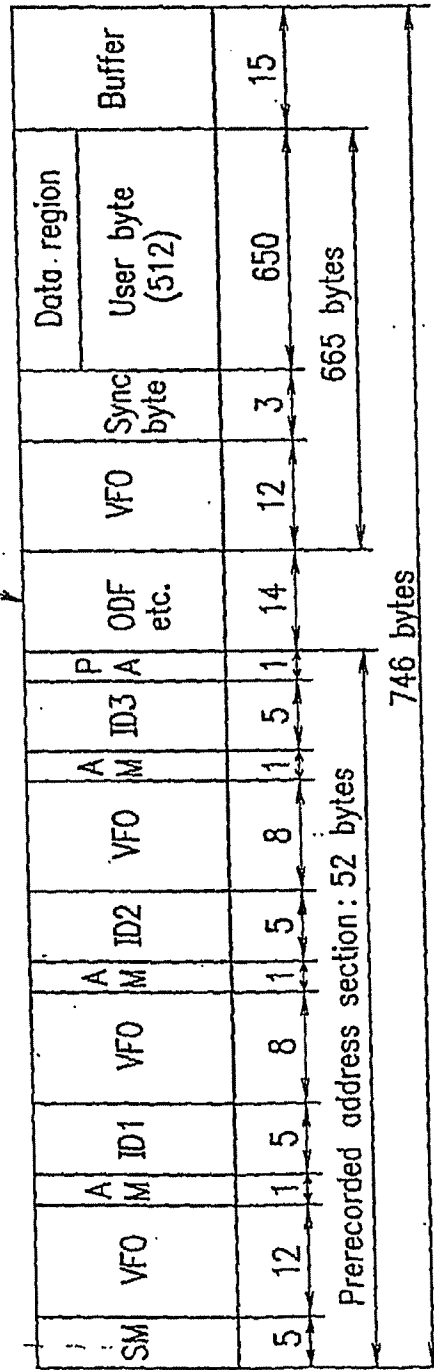

FIG. 7A

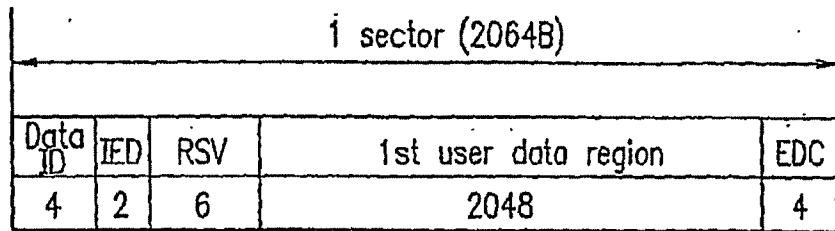

FIG. 7B

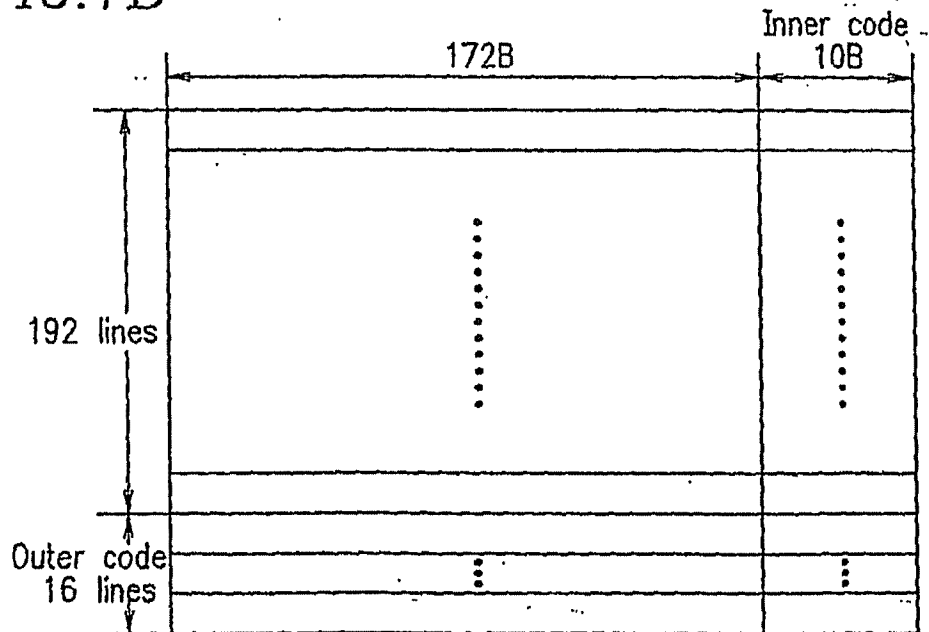

FIG. 7C

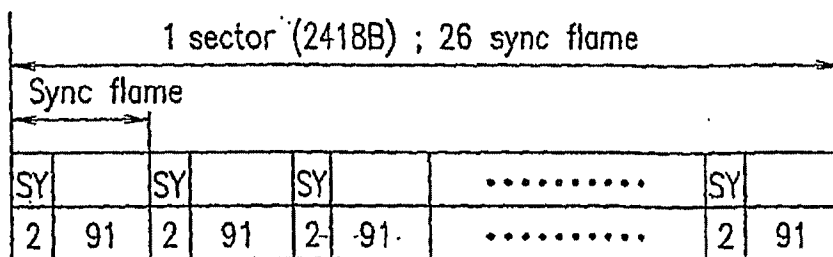

FIG. 8

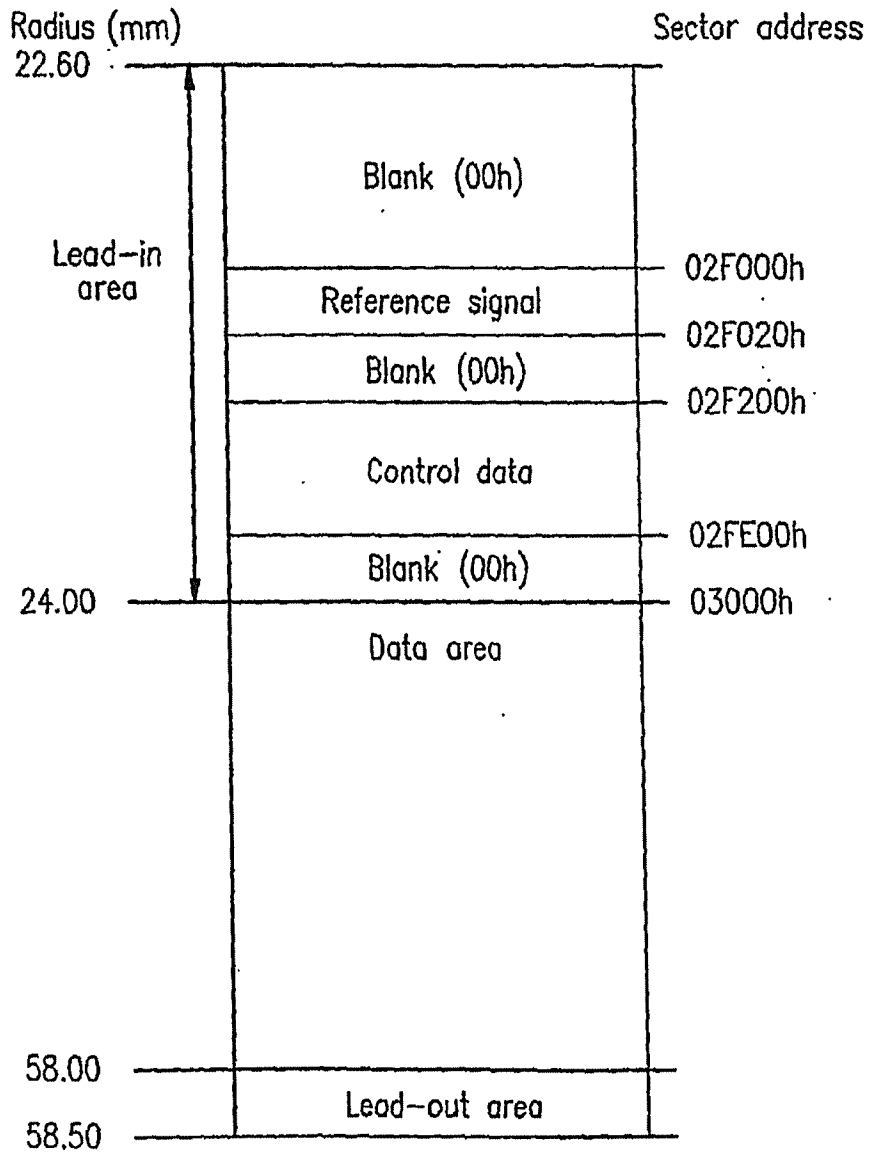

FIG. 9

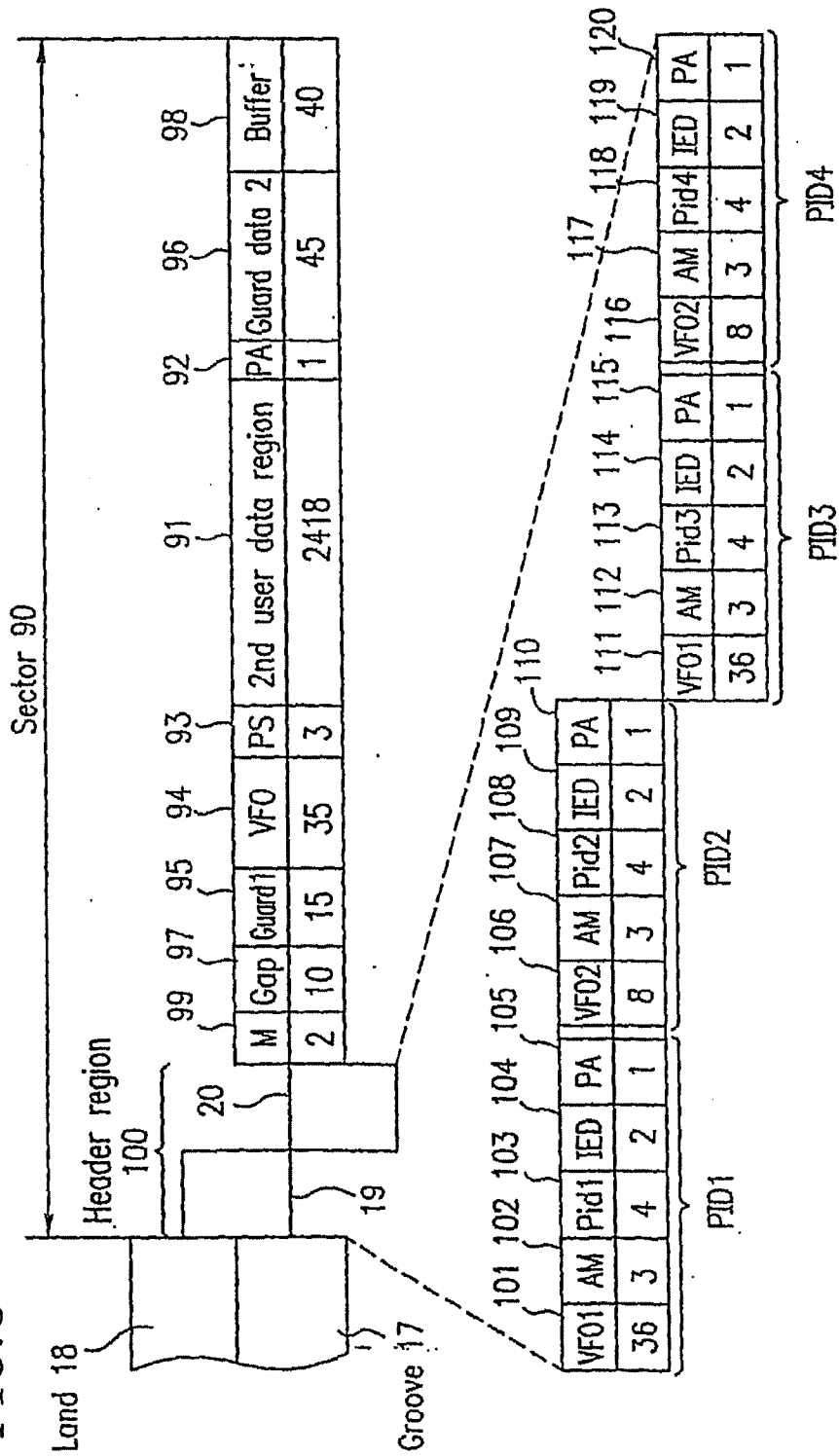
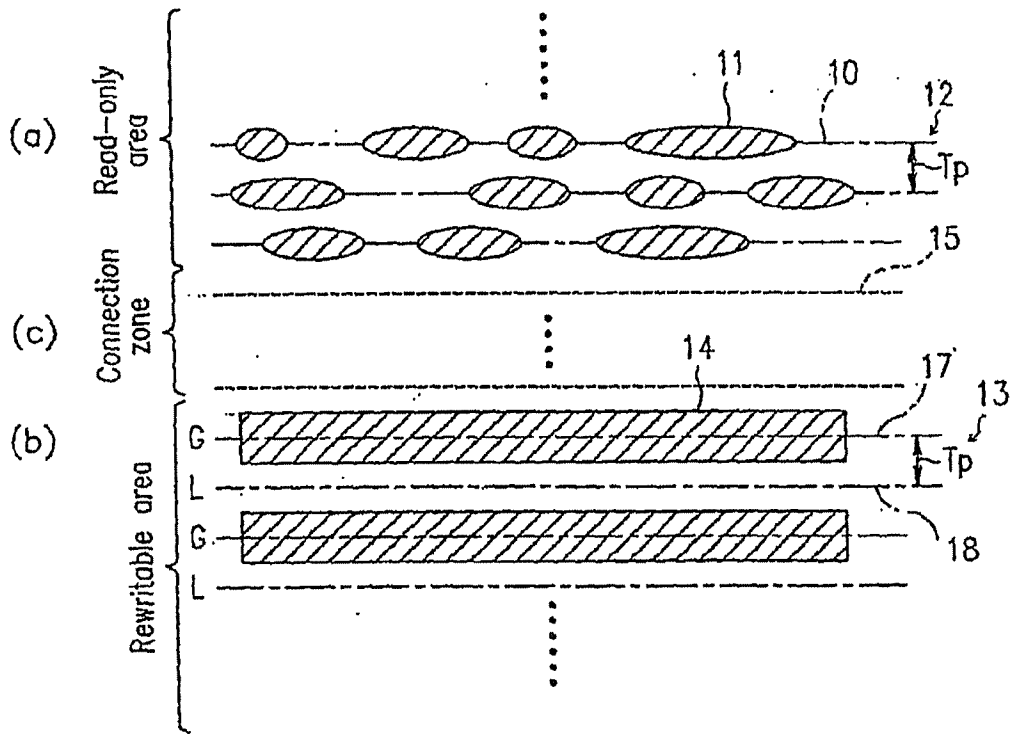

FIG. 10





(12) **EUROPEAN PATENT APPLICATION**

(88) Date of publication A3:
27.12.2006 Bulletin 2006/52

(51) Int Cl:
G11B 7/007 (2006.01) G11B 11/105 (2006.01)
G11B 27/32 (2006.01) G11B 7/00 (2006.01)
G11B 20/12 (2006.01)

(43) Date of publication A2:
02.01.2003 Bulletin 2003/01

(21) Application number: 02015540.4

(22) Date of filing: 20.10.1997

(84) Designated Contracting States:
DE FR GB

(30) Priority: 23.10.1996 JP 28049196

(62) Document number(s) of the earlier application(s) in
accordance with Art. 76 EPC:
00102960.2 / 1 006 514
97944184.7 / 0 936 601

(71) Applicant: **MATSUSHITA ELECTRIC INDUSTRIAL
CO., LTD.**
Kadoma-shi, Osaka 571-8501 (JP)

(72) Inventors:
• **Takemura, Yoshinari**
Sourakugun,
Kyoto 619-0237 (JP)

• **Ishida, Takashi**
Kyoto 614 (JP)
• **Ohara, Shunji**
Higashiosaka-shi,
Osaka 578 (JP)
• **Sato, Isao**
Neyagawa-shi,
Osaka 572 (JP)

(74) Representative: **Balsters, Robert et al**
Novagraaf International S.A.
25, avenue du Pailly
1220 Les Avanchets - Geneva (CH)

(54) **Optical disk**

(57) A rewritable optical disk is disclosed which is compatible with a read-only optical disk in which a read-only area has tracks divided into a plurality of first sectors, signals being pre-recorded in at least one of these first sectors under a predetermined reproduction format. The rewritable optical disc comprises a read-only area located in an inner portion in which read-only tracks are formed, and a rewritable area located in an outer portion in which rewritable tracks are formed. Each of the rewritable tracks is divided into second sectors, and the signal is recordable in the second sectors under a predetermined recording format which includes the predetermined reproduction format as a part thereof and further includes another part specific to the predetermined recording format.

FIG. 2

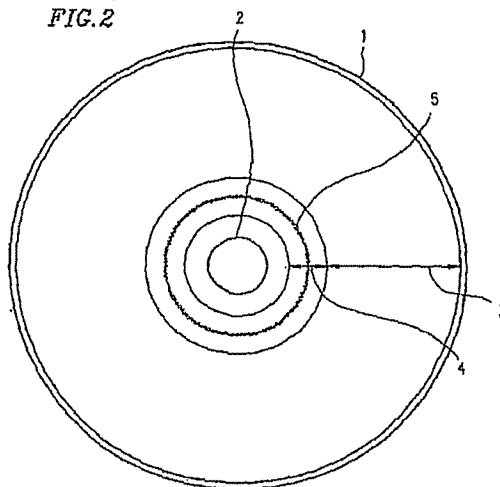



European Patent Office

EUROPEAN SEARCH REPORT

Application Number
EP 02 01 5540

DOCUMENTS CONSIDERED TO BE RELEVANT			
Category	Citation of document with indication, where appropriate, of relevant passages	Relevant to claim	CLASSIFICATION OF THE APPLICATION (IPC)
A	US 5 521 900 A (ANDO RYO ET AL) 28 May 1996 (1996-05-28) * column 6, line 8 - column 7, line 54; figure 4; table 2 * * column 3, line 58 - column 4, line 33; figures 1,2; table 1 * -----	1	INV. G11B7/007 G11B11/105 G11B27/32 G11B7/00 G11B20/12
A	EP 0 555 065 A (IBM) 11 August 1993 (1993-08-11) * page 11, line 10 - line 20 * -----	1	
A	EP 0 613 144 A (SONY CORP) 31 August 1994 (1994-08-31) * page 6, line 38 - page 8, line 10; figures 3,4 * * page 8, line 57 - page 9, line 27; figure 6 * -----	1	
E	WO 97/50082 A (MATSUSHITA ELECTRIC IND CO LTD ;MITSUBISHI ELECTRIC CORP (JP)) 31 December 1997 (1997-12-31) * page 19, line 1 - line 8 * * page 15, line 9 - page 19, line 15; figures 1,6 * -----	1	TECHNICAL FIELDS SEARCHED (IPC) G11B
P,X	EP 0 798 712 A2 (TOKYO SHIBAURA ELECTRIC CO [JP]) 1 October 1997 (1997-10-01) * column 5, line 50 * * column 4, line 2 - line 4 * -----	1	
The present search report has been drawn up for all claims			
Place of search The Hague		Date of completion of the search 16 November 2006	Examiner Holubov, Carol
CATEGORY OF CITED DOCUMENTS X : particularly relevant if taken alone Y : particularly relevant if combined with another document of the same category A : technological background O : non-written disclosure P : Intermediate document		T : theory or principle underlying the invention E : earlier patent document, but published on, or after the filing date D : document cited in the application L : document cited for other reasons & : member of the same patent family, corresponding document	

EPO Form 1503 08/02 (IndCorr)

ANNEX TO THE EUROPEAN SEARCH REPORT
ON EUROPEAN PATENT APPLICATION NO.

EP 02 01 5540

This annex lists the patent family members relating to the patent documents cited in the above-mentioned European search report. The members are as contained in the European Patent Office EDP file on The European Patent Office is in no way liable for these particulars which are merely given for the purpose of information.

16-11-2006

Patent document cited in search report		Publication date	Patent family member(s)	Publication date
US 5521900	A	28-05-1996	NONE	
EP 0555065	A	11-08-1993	AT 184417 T	15-09-1999
			AU 664061 B2	02-11-1995
			AU 3100493 A	05-08-1993
			BR 9300106 A	10-08-1993
			CA 2081179 A1	05-08-1993
			CN 1075230 A	11-08-1993
			DE 69326267 D1	14-10-1999
			DE 69326267 T2	20-04-2000
			ES 2136112 T3	16-11-1999
			HK 1008703 A1	14-04-2000
			ID 20158 A	15-10-1998
			JP 3122269 B2	09-01-2001
			JP 6084287 A	25-03-1994
			JP 2001052447 A	23-02-2001
			KR 9606847 B1	23-05-1996
			NZ 245391 A	21-12-1995
			US 5293565 A	08-03-1994
EP 0613144	A	31-08-1994	DE 69422535 D1	17-02-2000
			DE 69422535 T2	25-05-2000
			US 5687397 A	11-11-1997
WO 9750082	A	31-12-1997	CN 1228185 A	08-09-1999
			CN 1530940 A	22-09-2004
			DE 69715225 D1	10-10-2002
			DE 69715225 T2	08-05-2003
			EP 0929892 A1	21-07-1999
			HK 1019948 A1	09-05-2003
			ID 17546 A	08-01-1998
			JP 3160298 B2	25-04-2001
			JP 11513167 T	09-11-1999
			KR 2000022156 A	25-04-2000
			US 5923640 A	13-07-1999
EP 0798712	A2	01-10-1997	AT 194248 T	15-07-2000
			AU 695695 B2	20-08-1998
			AU 2233697 A	17-10-1997
			BR 9702185 A	16-03-1999
			CA 2222007 A1	02-10-1997
			CN 1183161 A	27-05-1998
			DE 69702361 D1	03-08-2000
			DE 69702361 T2	04-01-2001
			DK 798712 T3	11-09-2000
			ES 2150160 T3	16-11-2000

EPO FORM P065

For more details about this annex : see Official Journal of the European Patent Office, No. 12/82

EP 1 271 490 A3

ANNEX TO THE EUROPEAN SEARCH REPORT
ON EUROPEAN PATENT APPLICATION NO.

EP 02 01 5540

This annex lists the patent family members relating to the patent documents cited in the above-mentioned European search report. The members are as contained in the European Patent Office EDP file on The European Patent Office is in no way liable for these particulars which are merely given for the purpose of information.

16-11-2006

Patent document cited in search report	Publication date	Patent family member(s)	Publication date
EP 0798712	A2	GR 3033812 T3	31-10-2000
		HK 1003521 A1	11-05-2001
		JP 2848809 B2	20-01-1999
		JP 9259538 A	03-10-1997
		WO 9736296 A1	02-10-1997
		KR 262805 B1	01-08-2000
		NO 975381 A	23-01-1998
		RU 2174716 C2	10-10-2001
		TW 392151 B	01-06-2000
		US 5805547 A	08-09-1998

EPO FORM P0469

For more details about this annex : see Official Journal of the European Patent Office, No. 12/82